

MODERN TECHNOLOGIES AND LONG - TERM EXPERIENCE

■ V-D

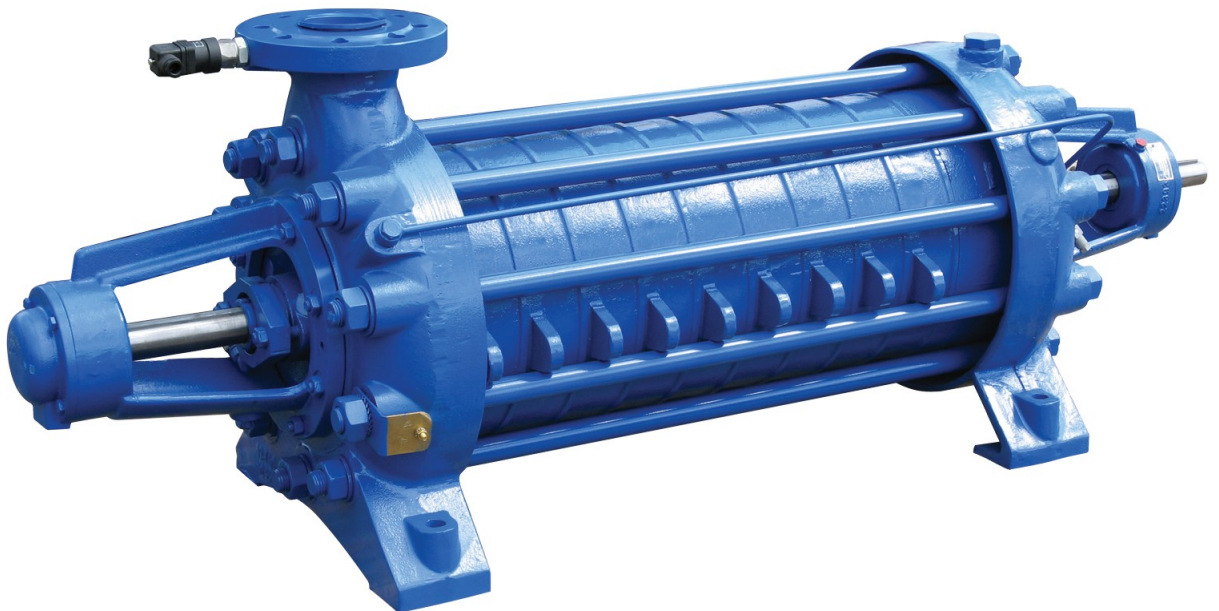

## CENTRIFUGAL MULTISTAGE HORIZONTAL PUMPS

**SIGMA PUMPY HRANICE, s.r.o.**  
Tovární č.p. 605, 753 01 Hranice I - Město, Czech Republic  
phone: +420 581 661 111, fax: +420 581 661 785  
e-mail: [sigmapumpy@sigmapumpy.com](mailto:sigmapumpy@sigmapumpy.com)  
[www.sigmapumpy.com](http://www.sigmapumpy.com)

426	12.05
05.11	

# Centrifugal Multistage Horizontal Pumps V-D

---

## Application

The pumps of V-D range are frequently used in water works, industrial workshops and in mining industry. They are used in the mining industry as auxiliary pumps to pump off polluted water in mines etc. The design of the pumps makes pumping both clean and polluted water of temperature up to 80°C possible. They are capable to pump waters containing up to 5% of mud with minor content of sand, coal dust or other solids. Size of such solids can be up to 0.3 — 0.5 mm and their content must not exceed 2% (percentage by weight). The higher content of sediments and solids in pumped liquid the heavier wearing of the pump due to solids.

## Description

The V-D pumps are of horizontal multistage centrifugal design with arrangement of its stages in line one behind other one in a number corresponding to required delivery head. They have been designed for severe working conditions.

## Design

The pump consists of suction body, discharge body and stages which are assembled between the bodies. This subassembly is drawn together by means of clamping bolts. The clamping bolts are designed outside liquid space of the pump. There is impeller with one-sided inlet working inside each stage. The impellers are sealed at the inlet sides with exchangeable wearing rings which are fixed into the suction body and the stage casings.

The shaft is protected by exchangeable sleeves which are both in suction body and discharge body as well as in body of the stage. The shaft is protected from effects of pumped liquid and against wearing along its length inside the pump as well as in both packings with the exchangeable sleeves. The end of the shaft for flexible coupling is taken out on the suction side of the pump. The complete rotor of the pump; i.e. all the impellers including shaft sleeves and rotor distance rings, is drawn together with nuts situated outside packing spaces. Before assembly of pump each rotor is perfectly statically and dynamically balanced so smooth operation without vibration of the pump is ensured.

Shaft of pump is sealed either with gland packing or with mechanical seal. Quality of the gland packing or mechanical seal is chosen acc. to the characteristics of pumped liquid and its temperature. The shaft seal on suction side is primed with pumped liquid by priming pipe from the discharge body which protects the pump against air sucking through the seal on suction side.

## Range of Delivery and Direction of Rotation

The pumps V-D are supplied as:

Range 1 - the pump only with bare end shaft

Range 9 - the pump coupled with complete flexible coupling to electric motor mounted on common base plate

The pumps are clockwise turning units when viewing from drive side. The direction is marked with arrow plate.

## Branches Layout

The discharge branch is always pointed upwards, suction branch is arranged to the right horizontally when viewed from drive.

## Materials

The shaft of the pump is made from steel. Shaft sleeves under packing are made of cast iron, sleeves protecting shaft in stages and wearing rings are made from bronze. Suction body, discharge body, diffusers and impellers are made from cast iron. On request different material version is possible.

## Standard accessories

Drain plugs, one set of gland packing cord and grease fill for bearings are delivered with each pump. Holes for vacuum pressure gauge and pressure gauge are plugged.

---

## Centrifugal Multistage Horizontal Pumps V-D

### Performance Table

The parameters following are valid for water, temperature  $t = 20\text{ }^{\circ}\text{C}$ , density  $\rho = 1000\text{ kg/m}^3$ , revolutions  $n = 1450\text{ R.P.M.}$

Pump model	Q l.sec <sup>-1</sup>	H m	P kW	m kg
VA-4/3-D	8,30	43	5,50	133
	11,70	38	7,25	
VA-4/4-D	8,30	60	8,00	151
	11,70	51	9,40	
VA-4/5-D	8,30	75	10,00	169
	11,70	64	11,80	
VA-4/6-D	8,30	90	12,00	192
	11,70	77	14,10	
VA-4/7-D	8,30	105	14,00	215
	11,70	89	16,50	
VA-4/8-D	8,30	120	16,00	238
	11,70	102	18,80	
VA-4/9-D	8,30	135	18,00	261
	11,70	115	21,20	
VA-4/10-D	8,30	150	20,00	284
	11,70	128	23,50	

Pump model	Q l.sec <sup>-1</sup>	H m	P kW	m kg
VL-4/3-D	3,35	43	3,30	133
	5,00	40	3,90	
	6,70	36	4,40	
VL-4/4-D	3,35	58	4,40	151
	5,00	54	5,20	
	6,70	48	5,90	
VL-4/5-D	3,35	72	5,50	169
	5,00	67	6,50	
	6,70	60	7,00	
VL-4/6-D	3,35	87	6,60	192
	5,00	82	7,80	
	6,70	72	8,40	
VL-4/7-D	3,35	103	7,70	215
	5,00	95	9,10	
	6,70	84	9,80	
VL-4/8-D	3,35	118	8,80	238
	5,00	109	10,40	
	6,70	95	11,20	
VL-4/9-D	3,35	132	9,90	261
	5,00	122	11,70	
	6,70	108	12,60	
VL-4/10-D	3,35	148	11,00	284
	5,00	136	13,00	
	6,70	120	14,00	

**Q** – flow rate  
**H** – total head  
**P** – power input  
**m** – bare end shaft pump weight

# Centrifugal Multistage Horizontal Pumps V-D

## Informative Sectional Drawing of Pump with Gland Packing

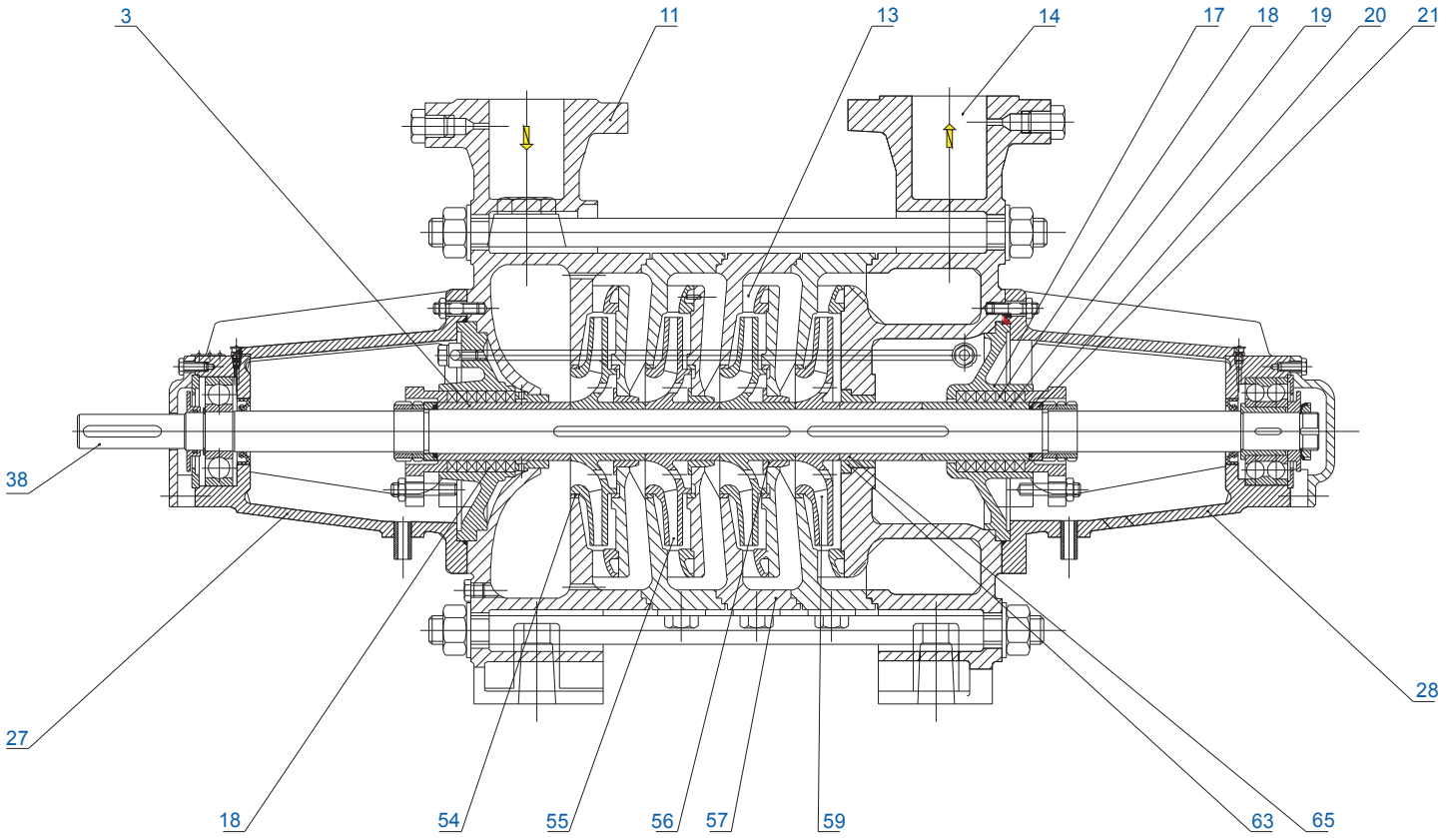

- |    |                         |    |                        |
|----|-------------------------|----|------------------------|
| 3  | Shaft sleeve            | 27 | Radial bearing housing |
| 11 | Suction body            | 28 | Axial bearing housing  |
| 13 | Diffuser                | 38 | Shaft                  |
| 14 | Discharge body          | 54 | Wearing ring           |
| 17 | Packing housing         | 55 | Impeller               |
| 18 | Braided cord 10x10-2880 | 56 | Stage bush             |
| 19 | Shaft sleeve            | 57 | Stage shell            |
| 20 | Ring 40x2               | 59 | Impeller – basic       |
| 21 | Rotor ring              | 63 | Discharge body bush    |
|    |                         | 65 | Shaft sleeve           |

# Centrifugal Multistage Horizontal Pumps V-D

## Informative Sectional Drawing of Pump with Mechanical Seal

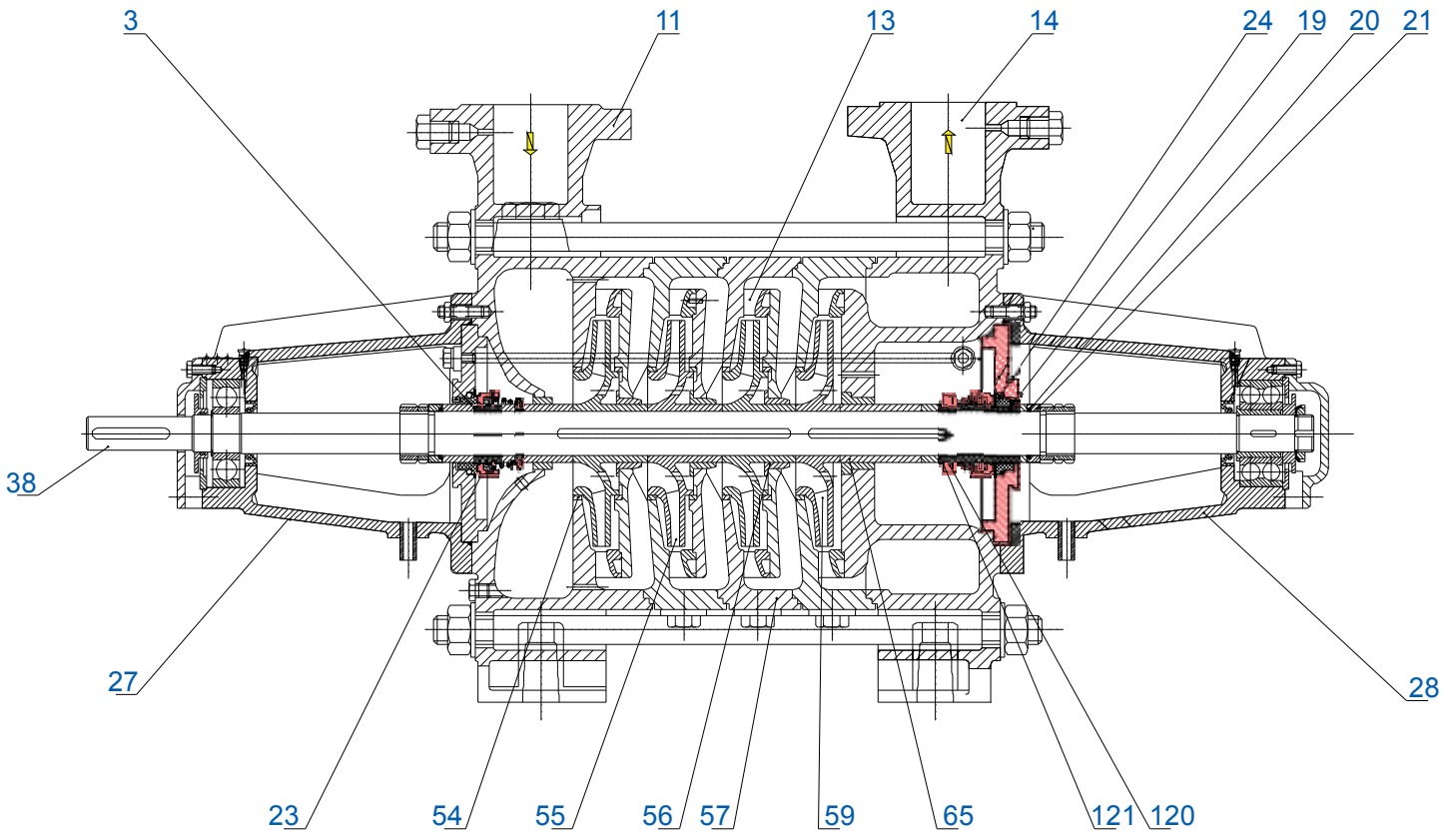

3	Shaft sleeve	27	Radial bearing housing
11	Suction body	28	Axial bearing housing
13	Diffuser	38	Shaft
14	Discharge body	54	Wearing ring
19	Shaft sleeve	55	Impeller
20	Ring 40x2	56	Stage bush
21	Rotor ring	57	Stage shell
23	Mechanical seal HTZ 55P-401S	59	Impeller – basic
24	Mechanical seal HTZ 55L-401S	65	Shaft sleeve
		120	Distance ring 55x65x10
		121	Retained ring 55

# Centrifugal Multistage Horizontal Pumps V-D

## Dimensioned Drawing

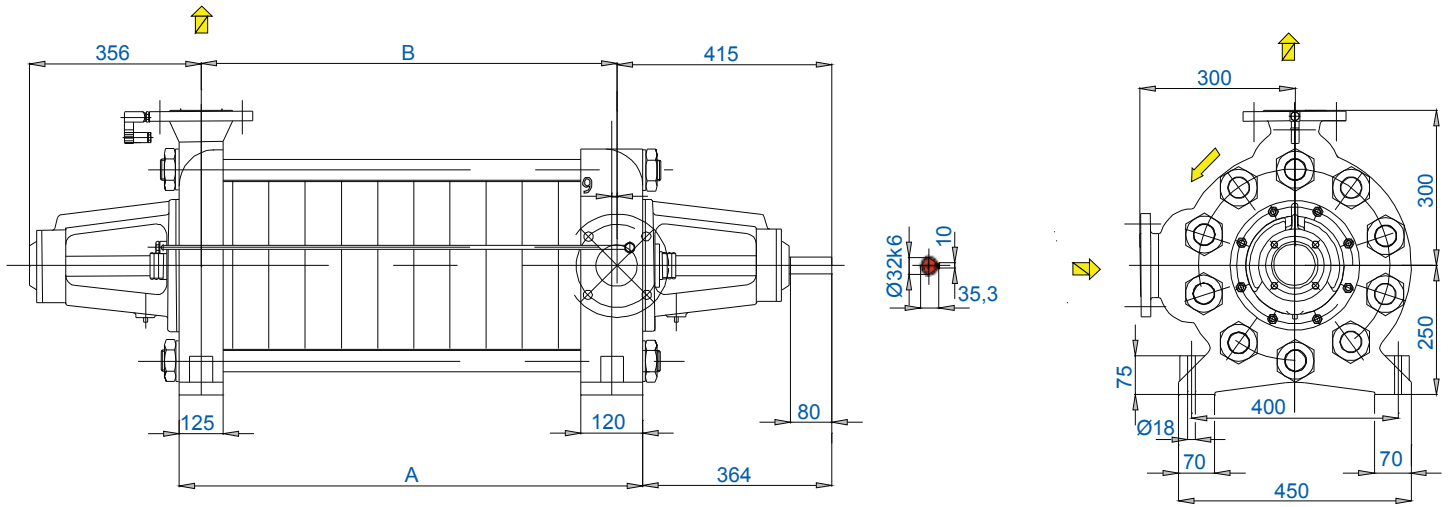

Stage Number	3	4	5	6	7	8	9	10
A	423	493	563	633	703	773	843	913
B	315	385	455	525	595	665	735	805

## Informative Performance Chart of the Pumps

